

KAMA////MCM



KAMA////MCM

КОМСОМОЛЬСКИЙ ПРОСПЕКТ, 98
ПЕРМЬ, РОССИЯ, 614010
Т/Ф: +7 (342) 241-19-51
241-17-34

INFO@KAMA-MSM.PERM.RU
KAMA-MSM.RU

Hydraulic Chucks



Hydraulic Chucks



Contents + + + + + + + + + +

	<p>液 压 刀 柄</p> <p>适用于CNC机床的切削加工（钻、扩、铰、铣等）；具有优良的阻尼减振性能与超高夹持精度（$\leq 0.003\text{mm}/4d$）；防尘排污结构设计，功能可靠持久；全系产品均精密动平衡。</p> <p>Hydraulic Chuck</p> <p>Suitable for CNC machine tool cutting (drilling, expanding, reaming, milling, etc.) ; Excellent damping performance and ultra-high clamping accuracy ($\leq 0.003\text{mm}/4d$) ; Dust-proof sewage structure design, reliable and durable function ; All products are precision dynamic balancing.</p> <p style="text-align: right;">02</p>
	<p>工 具 磨 液 压 刀 柄</p> <p>适用于CNC工具磨机床的工件夹持；满足刀具刃磨超高精度的要求（$\leq 0.002\text{mm}/4d$）；头部轮廓的特殊设计，能有效避免砂轮加工时的干涉；内部深腔结构能满足较长特制刀具的加工。</p> <p>Tool Grinding Hydraulic Chuck</p> <p>Workpiece clamping suitable for CNC tool grinding machine tool , It meets the requirement of ultra-high precision for tool grinding. ; The special design of head contour can effectively avoid interference in grinding wheel processing ; The inner deep cavity structure can satisfy the processing of longer special cutting tools.</p> <p style="text-align: right;">08</p>
	<p>可 调 液 压 刀 柄</p> <p>可调液压刀柄可有效补偿机床主轴的跳动与母线误差，有效延长刀具的使用寿命，提高产品加工质量并降低切削加工成本；特别适合于铰削加工。</p> <p>Adjustable Hydraulic Chuck</p> <p>The adjustable Hydraulic Chuck can effectively compensate the runout and bus error of the machine tool spindle, prolong the service life of the tool, improve the quality of the product and reduce the cutting cost, and is especially suitable for reaming.</p> <p style="text-align: right;">13</p>

液压刀柄的设计特点

Design Characteristics of Hydraulic Chuck

- 特殊表面处理，增强防锈能力，成就经典品质。
- 鲨鱼鳃防滑设计，融入人体工程科技，创新无处不在。

Special surface treatment enhances rust-proof ability and achieves classical quality
Shark gill anti-skid design, integrated with human engineering technology, innovation is everywhere.



- 匠心聚焦品质，4×d极致追求，精度不打折扣。

Creativity focuses on quality, 4×d is the ultimate pursuit, accuracy is not discounted. is everywhere.



- 超大扭矩设计，回归性能更本质，实现完美超越。

- 整体式结构，汲取11年制造精华，再造中国梦。

Super-large torque design, regression performance more essential, achieve perfect transcendence.

The whole structure takes 11 years to create the essence and reinvent the Chinese dream.

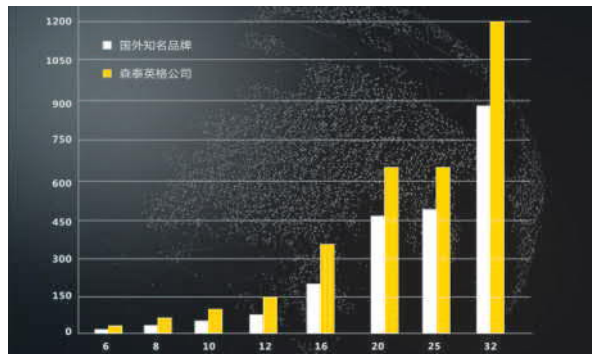

Hydraulic Chucks



- 选用液压刀柄，您需要理由：
Choose Hydraulic Chuck, you need reason

综合对比 Comprehensive contrast	液压刀柄 Hydraulic Chuck	弹簧夹头刀柄 Spring jacket handle
		
回转精度 Rotation accuracy	0.003mm(4xd)	0.015~0.03mm(4xd)
重复精度 Repeatability accuracy	0.002mm	不稳定
夹持力(φ20mm) Clamping force	640Nm	170Nm
径向刚性 Radial rigidity	★★★	★
减振效果 Damping effect	★★★	★
柔性夹持 Flexible clamping	★★	★★★★
操作性 Operability	★★★★	★
性价比 Cost performance	★★★★	★★

加工实例 Processing example

- 刀具型号：φ10硬质合金麻花钻
Tool type：Carbide twist drill
- 使用机床：加工中心(BT40)
Tool type：Carbide twist drill
- 零件材料：45钢(300HB~350HB)
Parts materials：steel
- 钻尖磨损(加工100个孔)
Drill point wear (Processing 100 holes)

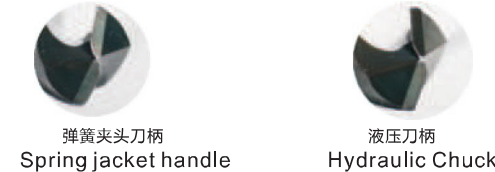

- 加工参数：
Processing parameters

Vc (切削速度) cutting speed	90m/min
fz (进给量) Feed rate	0.2mm/rev



HSK液压刀柄
HSK Hydraulic Chuck

DIN 69893



Handle diameter tolerance
柄径公差
h6

Rotation accuracy
回转精度
0.003mm

25000RPM
G2.5

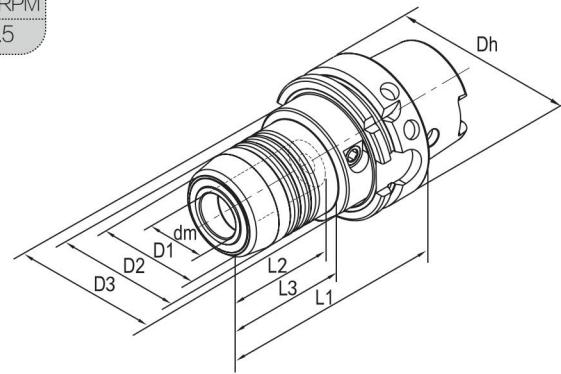

型号 Model	库存 Stock	[Icon]	尺寸Size (mm)							螺钉 Screw	卡簧 Collets	扳手 Hex wrench
			dm	D1	D2	D3	L1	L2	L3			
HSK63A-HCM06-70	●	63	6	22	26	50	70	37	24	HCSO05014C	—	TS5
HSK63A-HCM08-70	●	63	8	24	28	50	70	37	25	HCSO06014C	—	TS5
HSK63A-HCM10-80	●	63	10	26	30	50	80	41	35	HCSO08014C	—	TS5
HSK63A-HCM12-85	●	63	12	28	32	50	85	46	40	HCSO08014C	HC12	TS5
HSK63A-HCM14-85	○	63	14	30	34	50	85	46	40	HCSO08014C	—	TS5
HSK63A-HCM16-90	●	63	16	34	38	50	90	49	46	HCSO08014C	—	TS5
HSK63A-HCM18-90	○	63	18	36	40	50	90	49	47	HCSO12014C	—	TS5
HSK63A-HCM20-90	○	63	20	38	42	50	90	51	48	HCSO12014C	HC20	TS5
HSK63A-HCM25-120	○	63	25	53	57	63	120	57	59	HCSO12014C	—	TS6
HSK63A-HCM32-125	●	63	32	60	64	75	125	61	63	HCSO12014C	HC32	TS6
HSK100A-HCM06-75	○	100	6	22	26	50	75	37	26	HCSO05014C	—	TS5
HSK100A-HCM08-75	○	100	8	24	28	50	75	37	26	HCSO06014C	—	TS5
HSK100A-HCM10-90	○	100	10	26	30	50	90	41	42	HCSO08014C	—	TS5
HSK100A-HCM12-95	●	100	12	28	32	50	95	46	47	HCSO08014C	HC12	TS5
HSK100A-HCM16-100	○	100	16	34	38	50	100	49	53	HCSO08014C	—	TS5
HSK100A-HCM20-105	●	100	20	38	42	50	105	51	59	HCSO08014C	HC20	TS5
HSK100A-HCM25-110	○	100	25	53	57	63	110	57	62	HCSO12014C	—	TS6
HSK100A-HCM32-110	●	100	32	60	64	75	110	61	62	HCSO12014C	HC32	TS6

1.数据芯片孔及扳手孔为标配; 2.标准包装不含扳手, 需另购; 3.可按需求提供符合微量润滑 (MQL) 的产品, 更多信息详见11页; ●标准库存 ○订单生产

1.Data chip holes and wrench holes are standard matching 2.Standard packing does not contain wrenches and needs to be purchased separately. 3.Products conforming to MQL can be provided on demand. See page 11 for more information

附件Accessories	Dh=63	Dh=100
[Icon] 冷却液套管Coolant tubes	TU-HSK63	TU-HSK100
[Icon] 扳手Coolant tube wrenches	W-HSK63	W-HSK100

HSK液压刀柄
HSK Hydraulic Chuck



Handle diameter tolerance
柄径公差
h6

Rotation accuracy
回转精度
0.003mm

25000RPM
G2.5

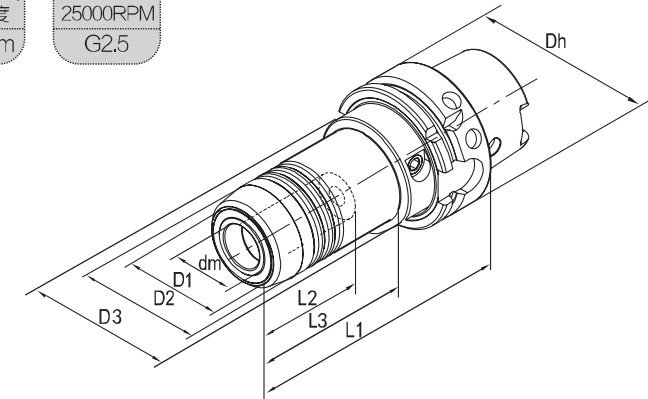

型号 Model	库存 Stock	[Icon]	尺寸Size (mm)							螺钉 Screw	卡簧 Collets	扳手 wrench
			dm	D1	D2	D3	L1	L2	L3			
HSK63A-HCM06-150	●	63	6	22	26	50	150	37	103	HCSO05014C	—	TS5
HSK63A-HCM08-150	●	63	8	24	28	50	150	37	104	HCSO06014C	—	TS5
HSK63A-HCM10-150	●	63	10	26	30	50	150	41	104	HCSO08014C	—	TS5
HSK63A-HCM12-150	●	63	12	28	32	50	150	46	105	HCSO08014C	—	TS5
HSK63A-HCM14-150	●	63	14	30	34	50	150	46	105	HCSO08014C	—	TS5
HSK63A-HCM16-150	●	63	16	34	38	50	150	49	106	HCSO08014C	—	TS5
HSK63A-HCM18-150	●	63	18	36	40	50	150	49	107	HCSO08014C	—	TS5
HSK63A-HCM20-150	●	63	20	38	42	50	150	51	108	HCSO08014C	—	TS5
HSK63A-HCM06-200	○	63	6	22	26	50	200	37	153	HCSO05014C	—	TS5
HSK63A-HCM08-200	○	63	8	24	28	50	200	37	154	HCSO06014C	—	TS5
HSK63A-HCM10-200	○	63	10	26	30	50	200	41	154	HCSO08014C	—	TS5
HSK63A-HCM12-200	●	63	12	28	32	50	200	46	155	HCSO08014C	—	TS5
HSK63A-HCM14-200	○	63	14	30	34	50	200	46	155	HCSO08014C	—	TS5
HSK63A-HCM16-200	○	63	16	34	38	50	200	49	156	HCSO08014C	—	TS5
HSK63A-HCM18-200	○	63	18	36	40	50	200	49	157	HCSO08014C	—	TS5
HSK63A-HCM20-200	●	63	20	38	42	50	200	51	158	HCSO08014C	—	TS5
HSK100A-HCM12-150	●	63	12	28	32	50	150	46	102	HCSO08014C	—	TS5
HSK100A-HCM20-150	●	63	20	38	42	50	150	51	104	HCSO08014C	—	TS5

1.数据芯片孔及扳手孔为标配; 2.标准包装不含扳手, 需另购; 3.可按需求提供符合微量润滑 (MQL) 的产品, 更多信息详见11页; ●标准库存 ○订单生产

1.Data chip holes and wrench holes are standard matching 2.Standard packing does not contain wrenches and needs to be purchased separately.

附件Accessories	Dh=63	Dh=100
[Icon] 冷却液套管Coolant tubes	TU-HSK63	TU-HSK100
[Icon] 扳手Coolant tube wrenches	W-HSK63	W-HSK100

BT液压刀柄
BT Hydraulic Chuck

JIS B6339



Handle diameter tolerance
柄径公差
h6

Rotation accuracy
回转精度
0.003mm

25000RPM
G2.5

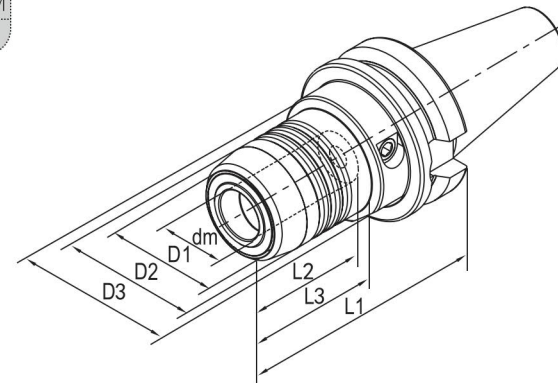

型号 Model	库存 Stock	BT	尺寸 Size (mm)							螺钉 Screw	卡簧 Collets	扳手 Hex wrench
			dm	D1	D2	D3	L1	L2	L3			
BT30-HCM06-50.8	○	30	6	23	26	46	50.8	37	15.6	HCSO05014C	—	TS4
BT30-HCM08-50.8	○	30	8	25	28	46	50.8	37	15.6	HCSO06014C	—	TS4
BT30-HCM10-50.8	○	30	10	27	30	46	50.8	41	15.6	HCSO08014C	—	TS4
BT30-HCM12-50.8	●	30	12	29	32	46	50.8	46	15.6	HCSO08014C	HC12	TS4
BT30-HCM16-90	○	30	16	34	38	50	90	49	50	HCSO08014C	—	TS5
BT30-HCM20-90	●	30	20	38	42	50	90	51	50	HCSO08014C	HC20	TS5
BT40-HCM06-90	○	40	6	22	26	50	90	37	43	HCSO05014C	—	TS5
BT40-HCM08-90	○	40	8	24	28	50	90	37	44.5	HCSO06014C	—	TS5
BT40-HCM10-90	○	40	10	26	30	50	90	41	44.5	HCSO08014C	—	TS5
BT40-HCM12-90	●	40	12	28	32	50	90	46	44.5	HCSO08014C	HC12	TS5
BT40-HCM14-90	○	40	14	30	34	50	90	46	44.5	HCSO08014C	—	TS5
BT40-HCM16-90	○	40	16	34	38	50	90	49	47.5	HCSO08014C	—	TS5
BT40-HCM18-90	○	40	18	36	40	50	90	49	47.5	HCSO08014C	—	TS5
BT40-HCM20-90	●	40	20	38	42	50	90	51	47.5	HCSO08014C	HC20	TS5
BT40-HCM25-83	○	40	25	53	57	72	83	57	25.5	HCSO12014C	—	TS6
BT40-HCM32-83	○	40	32	60	63	80	83	61	25.5	HCSO12014C	HC32	TS6
BT50-HCM06-90	○	40	6	22	26	44.5	90	37	29.5	HCSO05014C	—	TS5
BT50-HCM08-90	○	40	8	24	28	44.5	90	37	30	HCSO06014C	—	TS5
BT50-HCM10-90	○	40	10	26	30	44.5	90	41	31	HCSO08014C	—	TS5
BT50-HCM12-90	●	50	12	28	32	44.5	90	46	34	HCSO08014C	HC12	TS5
BT50-HCM16-90	○	40	16	34	38	44.5	90	49	34	HCSO08014C	—	TS5
BT50-HCM20-90	●	50	20	38	42	44.5	90	51	34	HCSO08014C	HC20	TS5
BT50-HCM25-90	○	50	25	53	57	66	90	57	34	HCSO12014C	—	TS6
BT50-HCM32-90	●	50	32	60	64	72	90	61	34	HCSO12014C	HC32	TS6

1.标准包装不含扳手，需另购；
2.可按需求提供符合微量润滑（MQL）的产品，更多信息详见11页；
1.Data chip holes and wrench holes are standard matching
2.Products conforming to MQL can be provided on demand. See page 11 for more information

● 标准库存 ○ 订单生产
● Standard stock ○ Production on order

BT液压刀柄
BT Hydraulic Chuck



Handle diameter tolerance
柄径公差
h6

Rotation accuracy
回转精度
0.003mm

25000RPM
G2.5

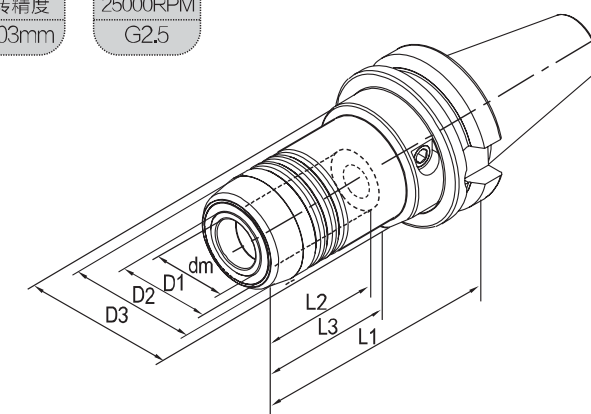

型号 Model	库存 Stock	BT	尺寸 Size (mm)							螺钉 Screw	卡簧 Collets	扳手 wrench
			dm	D1	D2	D3	L1	L2	L3			
BT40-HCM06-150	●	40	6	22	26	50	150	37	103	HCSO05014C	—	TS5
BT40-HCM08-150	●	40	8	24	28	50	150	37	104	HCSO06014C	—	TS5
BT40-HCM10-150	●	40	10	26	30	50	150	41	104	HCSO08014C	—	TS5
BT40-HCM12-150	●	40	12	28	32	50	150	46	105	HCSO08014C	—	TS5
BT40-HCM14-150	●	40	14	30	34	50	150	46	105	HCSO08014C	—	TS5
BT40-HCM16-150	●	40	16	34	38	50	150	49	106	HCSO08014C	—	TS5
BT40-HCM18-150	●	40	18	36	40	50	150	49	107	HCSO08014C	—	TS5
BT40-HCM20-150	●	40	20	38	42	50	150	51	107	HCSO08014C	—	TS5
BT40-HCM06-200	○	40	6	22	26	50	200	37	153	HCSO05014C	—	TS5
BT40-HCM08-200	○	40	8	24	28	50	200	37	154	HCSO06014C	—	TS5
BT40-HCM10-200	○	40	10	26	30	50	200	41	154	HCSO08014C	—	TS5
BT40-HCM12-200	●	40	12	28	32	50	200	46	155	HCSO08014C	—	TS5
BT40-HCM14-200	○	40	14	30	34	50	200	46	155	HCSO08014C	—	TS5
BT40-HCM16-200	○	40	16	34	38	50	200	49	156	HCSO08014C	—	TS5
BT40-HCM18-200	○	40	18	36	40	50	200	49	157	HCSO08014C	—	TS5
BT40-HCM20-200	●	40	20	38	42	50	200	51	157	HCSO08014C	—	TS5
BT50-HCM12-150	●	50	12	28	32	50	150	46	95	HCSO08014C	—	TS5
BT50-HCM20-150	●	50	20	38	42	50	150	51	95	HCSO08014C	—	TS5

标准包装不含扳手，需另购。
Data chip holes and wrench holes are standard matching

● 标准库存 ○ 订单生产
● Standard stock ○ Production on order

HSK液压刀柄
HSK Hydraulic Chuck

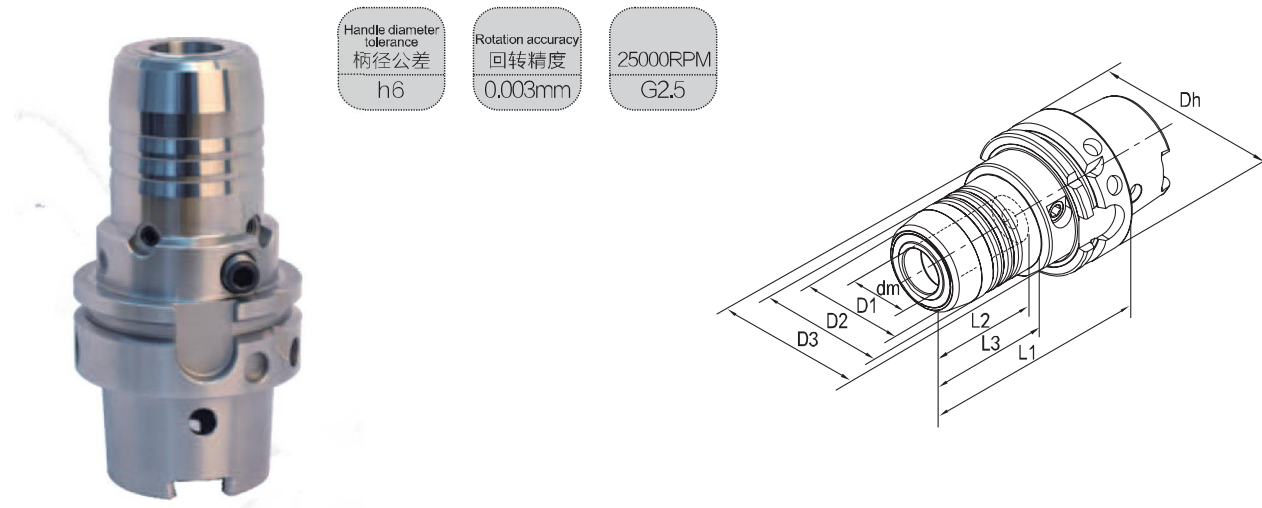

Handle diameter tolerance
柄径公差
h6

Rotation accuracy
回转精度
0.003mm

25000RPM
G2.5

型号 Model	库存 Stock		尺寸Size (mm)							螺钉 Screw	螺钉 Screw	扳手 wrench	
			dm	D1	D2	D3	L1	L2	L3				
HSK63A-HCZ12-85	●		63	12	28	32	50	85	47.5	40	HCSO08014C	RS06008A-HC	TS5/S3
HSK63A-HCZ16-95	○		63	16	34	38	50	95	55.5	46	HCSO08014C	RS06008A-HC	TS5/S3
HSK63A-HCZ20-90	●		63	20	38	42	50	90	51.5	48	HCSO08014C	RS06008A-HC	TS5/S3
HSK100A-HCZ12-95	●		100	12	28	32	50	95	47.5	47	HCSO08014C	RS06008A-HC	TS5/S3
HSK100A-HCZ16-100	○		100	16	34	38	50	100	55.5	53	HCSO08014C	RS06008A-HC	TS5/S3
HSK100A-HCZ20-105	●		100	20	38	42	50	105	51.5	59	HCSO08014C	RS06008A-HC	TS5/S3
HSK100A-HCZ25-110	●		100	25	53	57	63	110	59.5	62	HCSO12014C	RS06008A-HC	TS6

标准包装不含扳手，需另购。 ● 标准库存 ○ 订单生产
Data chip holes and wrench holes are standard matching. ● Standard stock ○ Production on order

BT液压刀柄
BT Hydraulic Chuck

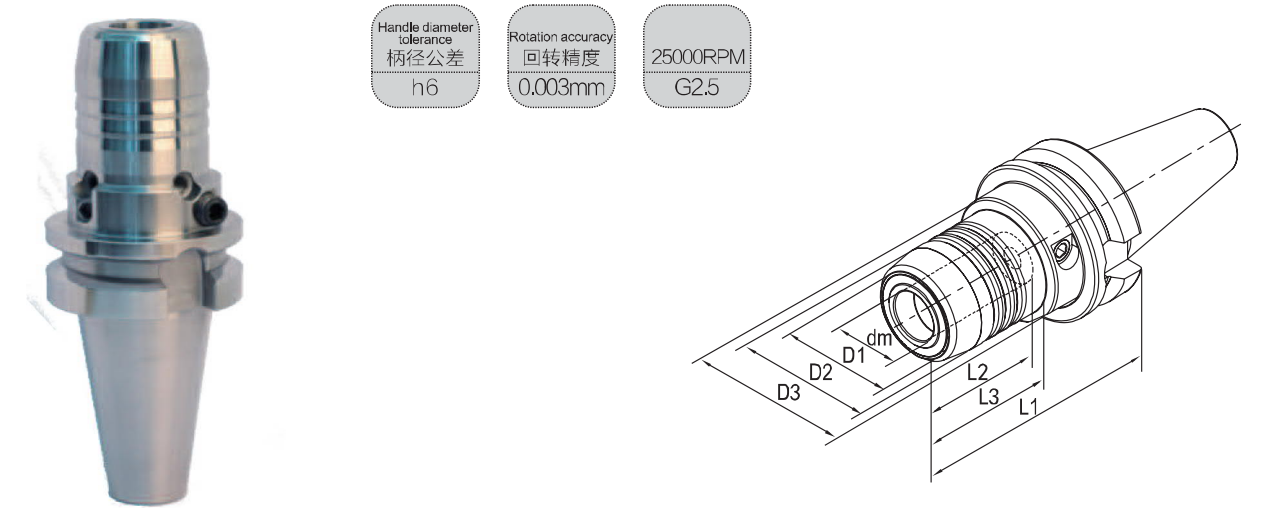

Handle diameter tolerance
柄径公差
h6

Rotation accuracy
回转精度
0.003mm

25000RPM
G2.5

型号 Model	库存 Stock		尺寸Size (mm)							螺钉 Screw	螺钉 Screw	扳手 wrench	
			dm	D1	D2	D3	L1	L2	L3				
BT40-HCZ12-90	●		40	12	28	32	50	90	47.5	44.5	HCSO08014C	RS06008A-HC	TS5/S3
BT40-HCZ16-95	○		40	16	34	38	50	95	55.5	47.5	HCSO08014C	RS06008A-HC	TS5/S3
BT40-HCZ20-90	●		40	20	38	42	50	90	51	47.5	HCSO08014C	RS06008A-HC	TS5/S3
BT50-HCZ12-100	●		50	12	28	32	50	100	47.5	44.5	HCSO08014C	RS06008A-HC	TS5/S3
BT50-HCZ16-105	○		40	16	34	38	50	105	55.5	47.5	HCSO08014C	RS06008A-HC	TS5/S3
BT50-HCZ20-105	●		50	20	38	42	50	105	51.5	50	HCSO08014C	RS06008A-HC	TS5/S3
BT50-HCZ25-120	●		50	25	53	57	63	120	59.5	62	HCSO12014C	RS06008A-HC	TS6

标准包装不含扳手，需另购。 ● 标准库存 ○ 订单生产
Data chip holes and wrench holes are standard matching. ● Standard stock ○ Production on order

附件Accessories	Dh=63	Dh=100
冷却液套管Coolant tubes	TU-HSK63	TU-HSK100
扳手Coolant tube wrenches	W-HSK63	W-HSK100

JT液压刀柄
JT Hydraulic Chuck

DIN69871



Handle diameter tolerance
柄径公差
h6

Rotation accuracy
回转精度
0.003mm

25000RPM
G2.5

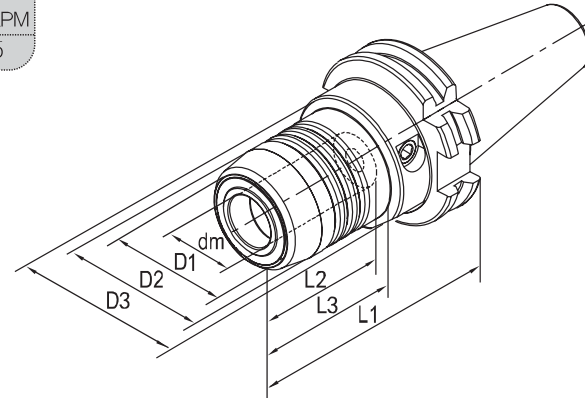

型号 Model	库存 Stock	📏	尺寸Size (mm)							🔩 螺钉 Screw	📏 卡簧 Collets	🔧 扳手 Hex wrench
			dm	D1	D2	D3	L1	L2	L3			
JT40-HCM06-80.5	○	40	6	22	26	50	80.5	37	29.5	HCSO05014C	—	TS5
JT40-HCM08-80.5	○	40	8	24	28	50	80.5	37	30	HCSO06014C	—	TS5
JT40-HCM10-80.5	○	40	10	26	30	50	80.5	41	31	HCSO08014C	—	TS5
JT40-HCM12-80.5	○	40	12	28	32	50	80.5	46	31.5	HCSO08014C	HC12	TS5
JT40-HCM16-80.5	○	40	16	34	38	50	80.5	49	33	HCSO08014C	—	TS5
JT40-HCM20-80.5	●	40	20	38	42	50	80.5	51	34	HCSO08014C	HC20	TS5
JT40-HCM25-80.5	○	40	25	53	57	72	80.5	57	25.5	HCSO12014C	—	TS6
JT40-HCM32-80.5	○	40	32	60	63	80	80.5	61	25.5	HCSO12014C	HC32	TS6
JT50-HCM06-80.5	○	40	6	22	26	50	80.5	37	29.5	HCSO05014C	—	TS5
JT50-HCM08-80.5	○	40	8	24	28	50	80.5	37	30	HCSO06014C	—	TS5
JT50-HCM10-80.5	○	40	10	26	30	50	80.5	41	31	HCSO08014C	—	TS5
JT50-HCM12-80.5	○	40	12	28	32	50	80.5	46	31.5	HCSO08014C	HC12	TS5
JT50-HCM16-80.5	○	50	16	34	38	50	80.5	49	34	HCSO08014C	—	TS5
JT50-HCM20-80.5	●	50	20	38	42	50	80.5	51	34	HCSO08014C	HC20	TS5
JT50-HCM25-80.5	○	50	25	53	57	66	80.5	57	34	HCSO12014C	—	TS6
JT50-HCM32-80.5	○	50	32	60	64	72	80.5	61	34	HCSO12014C	HC32	TS6

1.标准包装不含扳手，需另购；
2.可按需求提供符合微量润滑（MQL）的产品，更多信息详见07页；
1.Data chip holes and wrench holes are standard matching
2.Products conforming to MQL can be provided on demand. See page 07 for more information

● 标准库存 ○ 订单生产
● Standard stock ○ Production on order

微量润滑（MQL）应用简介

Brief introduction to application of Micro-lubrication (MQL)

什么是MQL？
What is MQL？

是将压缩气体与极微量润滑液混合并雾化后，喷射到加工区域，以对刀具和工件之间的加工部位进行有效的润滑与冷却的技术。

MQL可以大大减少“刀具-工件”和“刀具-切屑”之间的摩擦，起到抑制温升、降低刀具磨损、防止粘连和提高工件加工质量的作用，使用的润滑液很少，而效果却十分显著，既提高了工效，又不会对环境造成污染。

MQL所使用的润滑液用量非常少，而且MQL技术只要使用适当，加工后的刀具、工件和切屑都是干燥的，避免了后期的处理，清洁和干净的切屑经过压缩还可以回收使用，完全不污染环境，故又称之为准干式切削。

Compressed gas and very small amount of lubricant are mixed and atomized, and then sprayed into the processing area, which has effectively lubricated and cooled the processing parts between tools and workpieces.

MQL can greatly reduce the friction between "tool-workpiece" and "tool-chip", play the role of inhibiting temperature rise, reducing tool wear, placing adhesion and improving the quality of workpiece technicians. It uses very little lubricant, but the effect is very significant, that is, it improves work efficiency without causing pollution to the environment.

MQL uses very little lubricant, and MQL technology as long as the use of appropriate, processed tools, workpieces and chips are dry, avoiding post-processing, clean and clean chips after compression can also be recycled, no pollution to the environment, so it is also called quasi-dry cutting.

我们可根据客户的需求，在确定好细节后，为客户量身定制MQL系列产品：

We can customize MQL series products for customers according to their needs and after defining the details.

1.单通道自动换刀油雾刀柄：

1.Single-channel automatic tool changer oil mist handle

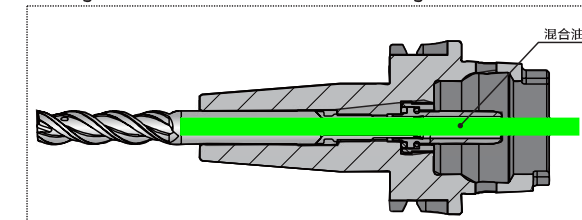

单通道油雾刀柄的油气混合是在机床主轴之外完成的并输送至刀柄内部的，通常情况下，其输送距离不超过8m，否则会产生严重的油气分离，从而使得润滑失效；同时，由于油气的输送需要一定的时间才能到达刀柄及刀具，所以它存在一定的滞后性；但是，相对于双通道系统而言，其机床要求低，对机床的改造简单、易行，成本相对较低。

Oil-gas mixing of single-channel oil mist tool holder is completed outside the spindle of machine tool and transported to the inside of tool holder. Usually, the transportation distance is not more than 8m, otherwise serious oil-gas separation will occur, which will lead to lubrication failure. At the same time, because oil-gas transportation takes a certain time to reach the tool holder and tool, it has a certain lag. As far as the dual-channel system is concerned, its machine tool requirements are low, and the modification of the machine tool is simple and easy, and the cost is relatively low.

2.单通道手动换刀油雾刀柄：

2.Single-channel manual tool changer oil mist handle

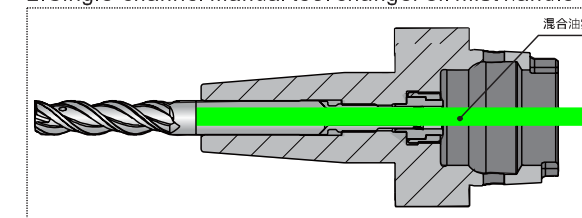

3.双通道自动换刀油雾刀柄：

3.Double-channel automatic tool changer oil mist handle

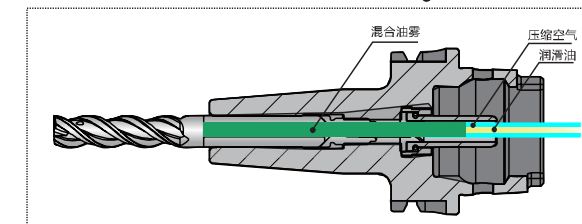

双通道油雾刀柄的油气混合是在刀柄内部完成的，在机床主轴内，设置有压缩气体与油液通道，将润滑油及压缩空气导入刀柄后，进行润滑油的雾化并混合。因此，它没有长距离油气输送的损耗，其功效最佳。但是，必须保证油雾润滑结构（长度调整螺钉与冷却液输送单元）的截面与刀具所有冷却液出口截面之和相一致。

The oil-gas mixing of the double-channel oil mist tool holder is accomplished in the tool holder. In the spindle of the machine tool, there are compressed gas and oil channels. After the lubricant and compressed air are introduced into the tool holder, the lubricant is atomized and mixed. Therefore, it has no loss of long-distance oil and gas transportation, and its effect is the best. However, it is necessary to ensure that the cross section of the oil mist lubrication structure (length adjustment screw and coolant delivery unit) is consistent with the sum of all coolant outlet cross sections of the tool.

JT工具磨液压刀柄
JTtool grinding Hydraulic Chuck

DIN69871



Handle diameter tolerance
柄径公差
h6

Rotation accuracy
回转精度
0.002mm

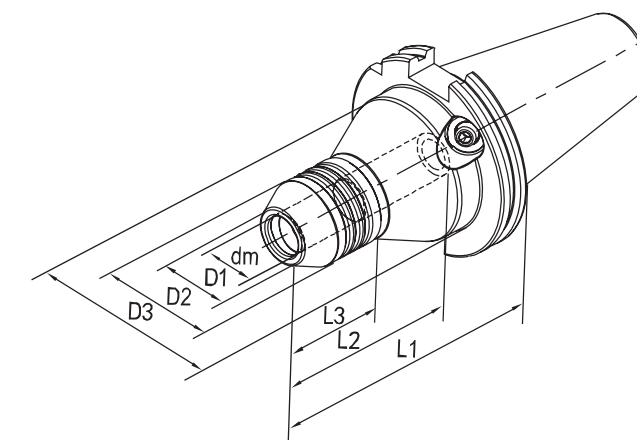

Hydraulic Chucks

工具磨液压刀柄

综合跳动 0.002mm



型号 Model	库存 Stock		尺寸Size (mm)							 卡簧 Collets	 扳手 Hex wrench
			dm	D1	D2	D3	L1	L2	L3		
JT50-HCM12-110M	●	50	12	21.5	36.5	60	110	50	55	HC12	TS5
JT50-HCM20-110M	●	50	20	28	42	70	110	95	47	HC20	TS5
JT50-HCM32-110M	●	50	32	40	54	70	110	95	62.5	HC32	TS5

1.标准包装不含扳手，需另购；
2.可按客户要求定制特殊要求产品，具体请联系本公司。

1.Standard packages do not contain wrenches and need to be purchased separately
2.Customized products with special requirements can be customized according to customers'needs. Please contact our company for details.

● 标准库存 ○ 订单生产
● Standard stock ○ Production on order

BT工具磨液压刀柄
BT tool grinding Hydraulic Chuck

JIS B6339



Handle diameter tolerance
柄径公差
h6

Rotation accuracy
回转精度
0.002mm

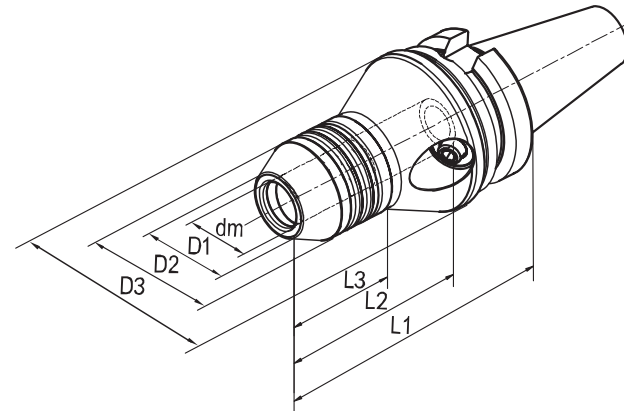

型号 Model	库存 Stock		尺寸Size (mm)								扳手 Hex wrench
			dm	D1	D2	D3	L1	L2	L3		
BT40-HCM12-110M	○	40	12	21.5	36.5	60	110	80	47	HC12	TS5
BT40-HCM20-110M	○	40	20	28	42	67	110	85	47	HC20	TS5

1.标准包装不含扳手，需另购；
2.可按客户要求定制特殊要求产品，具体请联系本公司。

1. Standard packages do not contain wrenches and need to be purchased separately
2. Customized products with special requirements can be customized according to customers' needs. Please contact our company for details.

● 标准库存 ○ 订单生产

HSK工具磨液压刀柄
HSK tool grinding Hydraulic Chuck

DIN69893



Handle diameter tolerance
柄径公差
h6

Rotation accuracy
回转精度
0.002mm

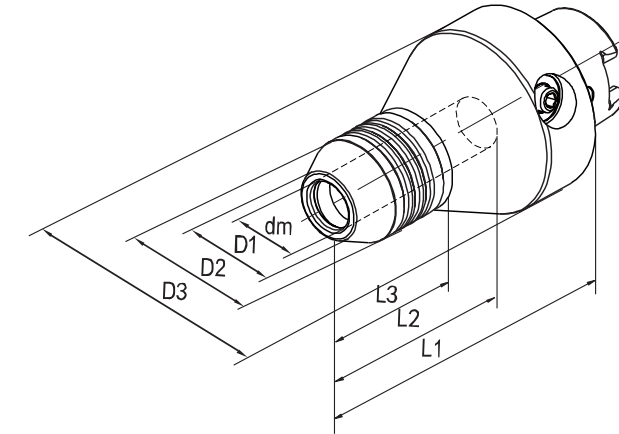

型号 Model	库存 Stock		尺寸Size (mm)								扳手 Hex wrench
			dm	D1	D2	D3	L1	L2	L3		
HSK63C-HCM12-110M	○	63	12	21.5	36.5	75	110	83	47	HC12	TS5
HSK63C-HCM20-110M	○	63	20	28	42	75	110	83	47	HC20	TS5
HSK63C-HCM32-110M	○	63	32	40	54	80	110	83	62.5	HC32	TS5

1.标准包装不含扳手，需另购；
2.可按客户要求定制特殊要求产品，具体请联系本公司。

1. Standard packages do not contain wrenches and need to be purchased separately
2. Customized products with special requirements can be customized according to customers' needs. Please contact our company for details.

● 标准库存 ○ 订单生产

工具制造业解决方案
Tool Manufacturing Solutions

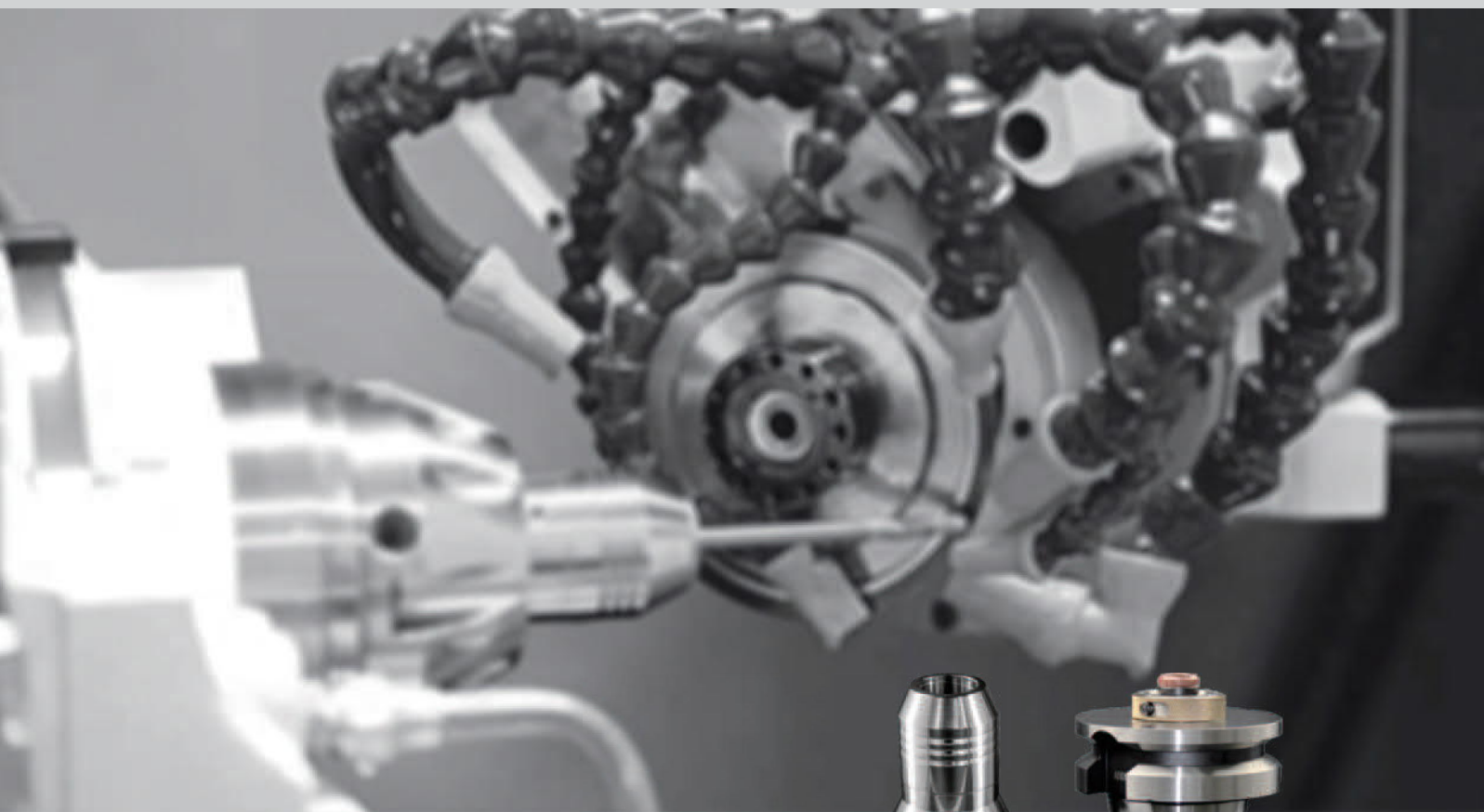

Hydraulic Chucks

Регулируемые гидравлические патроны

Погрешность не более $2\mu\text{m}$



可调液压刀柄模块
Adjustable Hydraulic Chuck Module



Handle diameter tolerance
柄径公差
h6

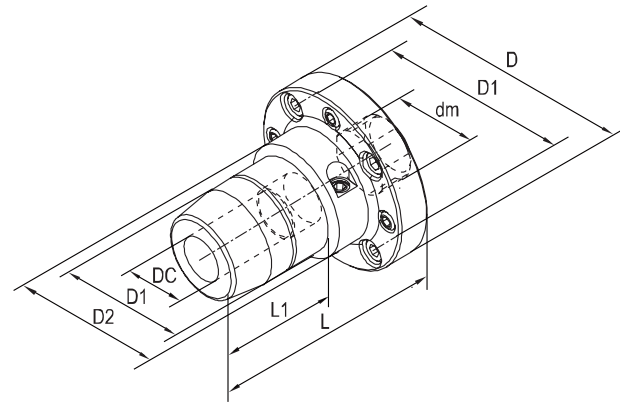

型号 Model	库存 Stock	dm	尺寸Size (mm)							螺钉 Screw	卡簧 Collets	扳手 Hex wrench
			dc	d1	d2	L1	L	D	D1			
DC70-HCM06-80	○	36	06	26	40	30	80	70	53	HCSO05014C	-	TS5
DC70-HCM08-80	○	36	08	28	40	30	80	70	53	HCSO06014C	-	TS5
DC70-HCM10-80	○	36	10	30	40	35	80	70	53	HCSO08014C	-	TS5
DC70-HCM12-85	○	36	12	32	40	40	85	70	53	HCSO08014C	HC12	TS5
DC80-HCM06-60	○	40	06	26	50	24	60	80	63	HCSO05014C	-	TS5
DC80-HCM08-60	○	40	08	28	50	25	60	80	63	HCSO06014C	-	TS5
DC80-HCM10-70	○	40	10	30	50	35	70	80	63	HCSO08014C	-	TS5
DC80-HCM12-80	○	40	12	32	50	44.5	80	80	63	HCSO08014C	HC12	TS5
DC80-HCM16-80	●	40	16	38	50	46	80	80	63	HCSO08014C	-	TS5
DC80-HCM20-80	●	40	20	42	50	47.5	80	80	63	HCSO08014C	HC20	TS5
DC100-HCM12-80	○	56	12	35	50	44.5	80	100	82	HCSO08014C	-	TS5
DC100-HCM16-80	○	56	16	38	50	46	80	100	82	HCSO08014C	-	TS5
DC100-HCM20-80	○	56	20	42	50	47.5	80	100	82	HCSO08014C	HC20	TS5
DC100-HCM25-90	●	56	25	57	63	59	90	100	82	HCSO12014C	-	TS6

1.标准包装不含扳手，需另购；
2.需配合可调刀柄一起使用，详见15、16、17页；
3.可按客户要求定制特殊要求产品，具体请联系本公司。

1. Standard packages do not contain wrenches and need to be purchased separately.
2. It should be used with adjustable tool handle. See page 15/16/17 for details.
3. Customized products with special requirements can be customized according to customers' needs. Please contact our company for details.

备件Spare Parts	dm=36	dm=40	dm=56
调节块 Shim	ZAD095	ZAD095	ZAD095
调节螺钉 Screw	RS08008-B	RS08008-B	RS08008-B

附件Accessories	dm=36	dm=40	dm=56
扳手 Hex wrench	S4	S4	S4

BT可调刀柄主柄
BT Adjustable Hydraulic Chuck Master Module

JIS B6339

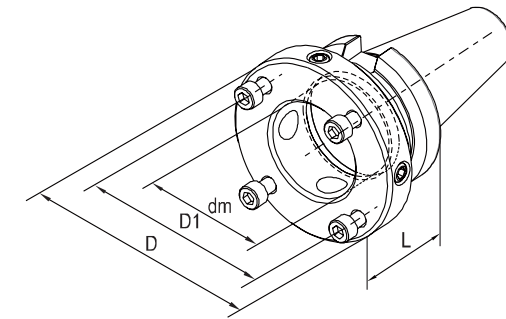

型号 Model	库存 Stock	锥度 Taper	尺寸Size (mm)			
			dm	D	D1	L
BT30-DC70-50	○	30	36	70	53	50
BT30-DC80-50	○	30	40	80	63	50
BT40-DC70-55	○	40	36	70	53	55
BT40-DC80-55	●	40	40	80	63	55
BT40-DC100-60	○	40	56	100	82	60
BT50-DC70-70	○	50	36	70	53	70
BT50-DC80-70	●	50	40	80	63	70
BT50-DC100-70	●	50	56	100	82	70

1.需配合可调液压刀柄模块一起使用，详见14页；
2.可按客户要求定制特殊要求产品，具体请联系本公司。

● 标准库存 ○ 订单生产
● Standard stock ○ Production on order

1. It should be used with adjustable tool handle. See page 15/16/17 for details.
2. Customized products with special requirements can be customized according to customers' needs. Please contact our company for details.

备件Spare Parts	dm=36	dm=40	dm=56
压紧螺钉 Screw	MS06020	MS06020	MS08025
径向调节螺钉 Screw	RS08016-B	RS08016-B	RS10020-B

附件Accessories	dm=36	dm=40	dm=56
扳手 Torx wrench	S5	S5	S6
	S4	S4	S5

JT可调刀柄手柄
JT Adjustable Hydraulic Chuck Master Module

DIN69871

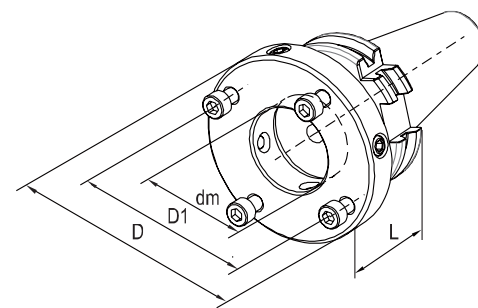

型号 Model	库存 Stock		尺寸Size (mm)			
			dm	D	D1	L
JT40-DC70-55	○	40	36	70	53	55
JT40-DC80-55	○	40	40	80	63	55
JT40-DC100-60	○	40	56	100	82	60
JT50-DC70-50	○	50	36	70	53	50
JT50-DC80-50	○	50	40	80	63	50
JT50-DC100-60	○	50	56	100	82	60

1.需配合可调液压力柄模块一起使用，详见14*页；
2.可按客户要求定制特殊要求产品，具体请联系本公司。
1.It should be used with adjustable Hydraulic Chuck module. See page 14 for details.
2.Customized products with special requirements can be customized according to customers'needs. Please contact our company for details.

● 标准库存 ○ 订单生产
● Standard stock ○ Production on order

备件Spare Parts	dm=36	dm=40	dm=56
压紧螺钉 Screw	MS06020	MS06020	MS08025
径向调节螺钉 Screw	RS08016-B	RS08016-B	RS10020-B

附件Accessories	dm=36	dm=40	dm=56
扳手 Torx wrench	S5	S5	S6
	S4	S4	S5

HSK可调刀柄手柄
HSK Adjustable Hydraulic Chuck Master Module

DIN 69893

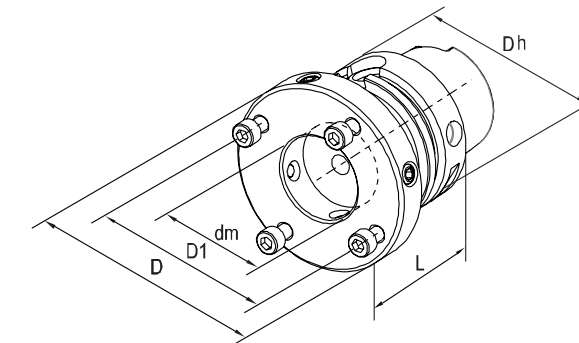

型号 Model	库存 Stock		尺寸Size (mm)			
			dm	D	D1	L
HSK50A-DC70-65	○	50	36	70	53	65
HSK50A-DC80-65	○	50	40	80	63	65
HSK63A-DC70-65	○	63	36	70	53	65
HSK63A-DC80-65	●	63	40	80	63	65
HSK63A-DC100-70	○	63	56	100	82	70
HSK100A-DC70-50	○	100	36	70	53	50
HSK100A-DC80-50	●	100	40	80	63	50
HSK100A-DC100-70	●	100	56	100	82	70

1.数据芯片孔及扳手孔为标配；
2.需配合可调液压力柄模块一起使用，详见14*页；
3.可按客户要求定制特殊要求产品，具体请联系本公司。
1.Data chip holes and wrench holes are standard matching
2.It should be used with adjustable Hydraulic Chuck module. See page 14 for details.
3.Customized products with special requirements can be customized according to customers'needs. Please contact our company for details.

● 标准库存 ○ 订单生产
● Standard stock ○ Production on order

备件Spare Parts	dm=36	dm=40	dm=56
压紧螺钉 Screw	MS06020	MS06020	MS08025
径向调节螺钉 Screw	RS08016-B	RS08016-B	RS10020-B

附件Accessories	dm=36	dm=40	dm=56
扳手 Torx wrench	S5	S5	S6
	S4	S4	S5

附件Accessories	Dh=63	Dh=100
冷却液套管 Coolant tubes	TU-HSK63	TU-HSK100
扳手 Coolant tube wrenches	W-HSK63	W-HSK100

可调液压刀柄使用说明

Instructions for the use of adjustable Hydraulic Chuck:

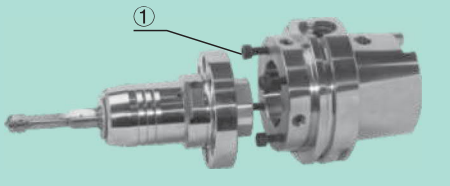

①

将可调液压刀柄模块与刀柄的连接部分彻底清洗干净，无油污；再将刀柄模块与刀柄连接在一起，用端面压紧螺钉①进行预紧（注意：切勿拧紧）。

The connection part between adjustable hydraulic tool holder module and tool holder is thoroughly clean and free of oil pollution. Then the tool holder module is connected with the tool holder and pre-tightened with end pressing screw 1 (note: do not tighten). Compression can also be recycled, no pollution to the environment, so it is also called quasi-dry cutting.

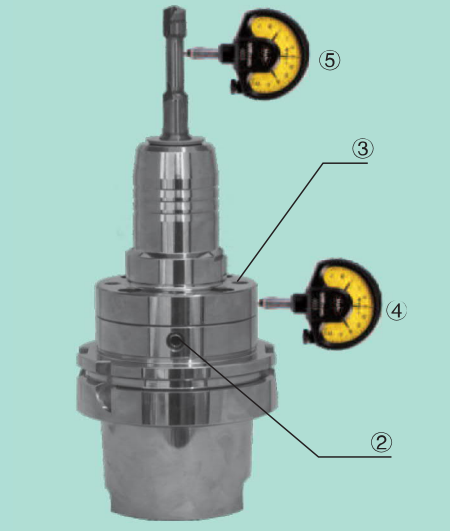

②

转动机床主轴，找出表④连接处外圆的最高点，旋动最高点处的径向调节螺钉②，将表④的移动量设定为跳动误差的一半。重复以上操作，直至跳动误差小于0.002mm。

Turn the spindle of the machine tool, find out the highest point of the outer circle at the connection of table 4, rotate the radial adjusting screw 2 at the highest point, and set the movement of Table 4 to half of the run-out error. Repeat the above operation until the jump error is less than 0.002mm.

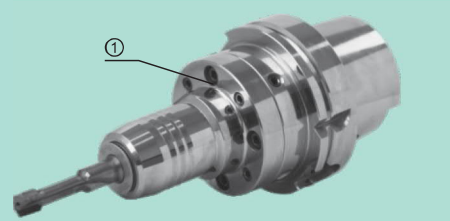

③

转动机床主轴，找出刀具前端（表⑤）对刀环的最高点，旋动最高点处对应的端面调节螺钉③，将表⑤的移动量设定为跳动误差的一半。重复以上操作，直至跳动误差小于0.002mm。

Turn the spindle of the machine tool, find out the highest point of the outer circle at the connection of table 4, rotate the radial adjusting screw 2 at the highest point, and set the movement of Table 4 to half of the run-out error. Repeat the above operation until the jump error is less than 0.002mm.

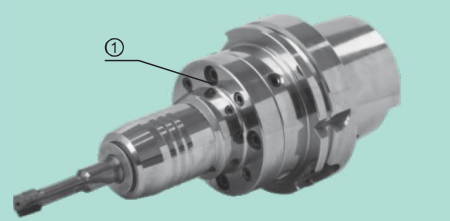

④

交叉紧固端面压紧螺钉①，完成锁紧。最后再次检查跳动应该小于等于0.002mm。

Cross-tightening end face pressing screw 1, complete locking. Finally, check again that the jump should be less than or equal to 0.002mm.

+ 加工实例 Processing examples:

- 刀具型号：φ32 PCD铰刀 Tool type : Carbide twist drill
- 使用机床：加工中心 Tool type : Carbide twist drill
- 零件材料：铝合金 Parts materials : steel



未采用系统误差校正的切削系统：
系统综合跳动>0.02mm

Cutting System without System Error Correction:
System Comprehensive Runout > 0.02mm



采用系统误差校正的切削系统：
可调液压刀柄，系统综合跳动<0.001mm

Cutting system with system error correction: adjustable Hydraulic Chuck., system comprehensive jump < 0.001mm

液压卡簧 Hydraulic collets



精度 precision
5um

- 切削刀具必须为圆柱形，使用内冷时，必须有一个通孔。
- 切削刀具必须完全接触长度为L1的液压卡簧型腔，否则会对液压卡簧及刀柄产生永久性的损伤。
- 液压卡簧必须完全插入到液压柄孔径中，直至肩部与液压柄前端面贴合。
- 切削刀具的柄径公差等级为h6。

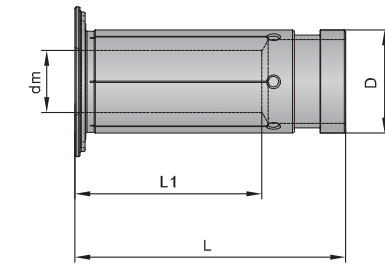

Cutting tools must be cylindrical and have a through hole when cooling. Cutting tools must fully contact the Hydraulic collets cavity with the length of L1. Otherwise, the Hydraulic collets and the tool handle will be permanently damaged. The Hydraulic collets must be fully inserted into the aperture of the Hydraulic Chuck until the shoulder fits the front end of the Hydraulic Chuck. The tolerance grade of the handle diameter of the cutting tool is h6.

型号 Model	库存 Stock	尺寸Size (mm)			
		d	dm	L1	L
HC12-3	●	3	12	16.5	47.5
HC12-4	●	4	12	16.5	47.5
HC12-5	●	5	12	16.5	47.5
HC12-6	●	6	12	24.0	47.5
HC12-8	●	8	12	25.5	47.5
HC20-3	●	3	20	17.5	52.5
HC20-4	●	4	20	17.5	52.5
HC20-5	●	5	20	17.5	52.5
HC20-6	●	6	20	25.5	52.5
HC20-7	●	7	20	28.0	52.5
HC20-8	●	8	20	28.0	52.5
HC20-9	●	9	20	32.5	52.5
HC20-10	●	10	20	32.5	52.5
HC20-11	●	11	20	36.0	52.5
HC20-12	●	12	20	36.0	52.5
HC20-13	●	13	20	36.5	52.5
HC20-14	●	14	20	37.0	52.5
HC20-15	●	15	20	37.0	52.5
HC20-16	●	16	20	37.5	52.5
HC32-6	●	6	32	25.5	63.5
HC32-8	●	8	32	27.5	63.5
HC32-10	●	10	32	30.5	63.5
HC32-12	●	12	32	30.5	63.5
HC32-14	●	14	32	32.5	63.5
HC32-16	●	16	32	40.5	63.5
HC32-18	●	18	32	40.5	63.5
HC32-20	●	20	32	40.5	63.5
HC32-25	●	25	32	48.5	63.5

● 标准库存 ○ 订单生产
● Standard stock ○ Production on order

高精度液压卡簧 High Precision Hydraulic collets



精度 precision
3um

- 切削刀具必须为圆柱形,使用内冷时,必须有一个通孔。
- 切削刀具必须完全接触长度为L1的液压卡簧型腔,否则会对液压卡簧及刀柄产生永久性的损伤。
- 液压卡簧必须完全插入到液压柄孔径中,直至肩部与液压柄前端面贴合。
- 切削刀具的柄径公差等级为h6。

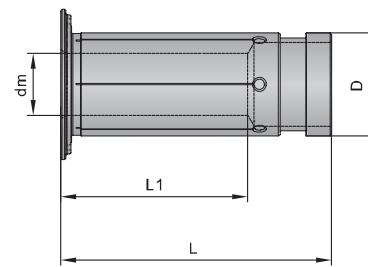

Cutting tools must be cylindrical and have a through hole when cooling.
Cutting tools must fully contact the Hydraulic collets cavity with the length of L1. Otherwise, the Hydraulic collets and the tool handle will be permanently damaged.
The Hydraulic collets must be fully inserted into the aperture of the Hydraulic Chuck until the shoulder fits the front end of the Hydraulic Chuck.
The tolerance grade of the handle diameter of the cutting tool is h6.

型号 Model	库存 Stock	尺寸Size (mm)			
		d	dm	L1	L
HC12-3M	●	3	12	16.5	47.5
HC12-4M	●	4	12	16.5	47.5
HC12-5M	●	5	12	16.5	47.5
HC12-6M	●	6	12	24.0	47.5
HC12-8M	●	8	12	25.5	47.5
HC20-3M	●	3	20	17.5	52.5
HC20-4M	●	4	20	17.5	52.5
HC20-5M	●	5	20	17.5	52.5
HC20-6M	●	6	20	25.5	52.5
HC20-7M	●	7	20	28.0	52.5
HC20-8M	●	8	20	28.0	52.5
HC20-9M	●	9	20	32.5	52.5
HC20-10M	●	10	20	32.5	52.5
HC20-11M	●	11	20	36.0	52.5
HC20-12M	●	12	20	36.0	52.5
HC20-13M	●	13	20	36.5	52.5
HC20-14M	●	14	20	37.0	52.5
HC20-15M	●	15	20	37.0	52.5
HC20-16M	●	16	20	37.5	52.5
HC32-6M	●	6	32	25.5	63.5
HC32-8M	●	8	32	27.5	63.5
HC32-10M	●	10	32	30.5	63.5
HC32-12M	●	12	32	30.5	63.5
HC32-14M	●	14	32	32.5	63.5
HC32-16M	●	16	32	40.5	63.5
HC32-18M	●	18	32	40.5	63.5
HC32-20M	●	20	32	40.5	63.5
HC32-25M	●	25	32	48.5	63.5

● 标准库存 ○ 订单生产
● Standard stock ○ Production on order

液压刀柄测试棒 Hydraulic Chuck Test Rod

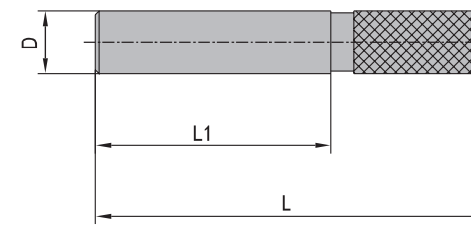

型号 Model	库存 Stock	尺寸Size (mm)		
		D	L	L1
HC06-TB	○	6	70	40
HC08-TB	○	8	70	40
HC10-TB	○	10	75	45
HC12-TB	○	12	80	50
HC14-TB	○	14	90	55
HC16-TB	○	16	90	55
HC20-TB	○	20	90	55
HC25-TB	○	25	90	55
HC32-TB	○	32	90	55

● 标准库存 ○ 订单生产
● Standard stock ○ Production on order

* 请定期检测液压刀柄的夹紧功能。检验时,将检测棒(需单独订购)装于孔内,直至底端,再旋拧施压螺钉至刚好将检测棒夹紧(可用手试拧检测棒,待用手刚好不能旋动即为初始状态),然后继续旋拧施压螺钉至底部,并计算施压圈数,如果施压圈数满足1.5圈(HC06, HC08)或者大于2圈(HC10以上规格),则说明该刀柄具有夹紧功能,否则请将液压刀柄寄回我公司进行检测、维修。

* 液压刀柄在非工作状态或未装夹刀具时,请将施压螺钉旋至放松状态,将刀柄擦拭干净并涂上防锈剂后存放。

Please check the clamping function of Hydraulic Chuck regularly. When inspecting, clamp the test rod (ordered separately) in the hole until the bottom, and clamp the test rod just after the screw is screwed (the test rod can be screwed by hand, and then continue to screw the pressure screw to the bottom, and calculate the number of pressure cycles if the number of pressure cycles meets 1.5 cycles (HC06, HC08) or more than 2 cycles (HC10). Specification), it shows that the tool holder has clamping function, otherwise please send the Hydraulic Chuck back to our company for inspection and maintenance.

When Hydraulic Chuck is not in working state or without clamping tool, please screw the pressure screw to relax state, wipe the tool holder clean and coat with antirust agent and store it.

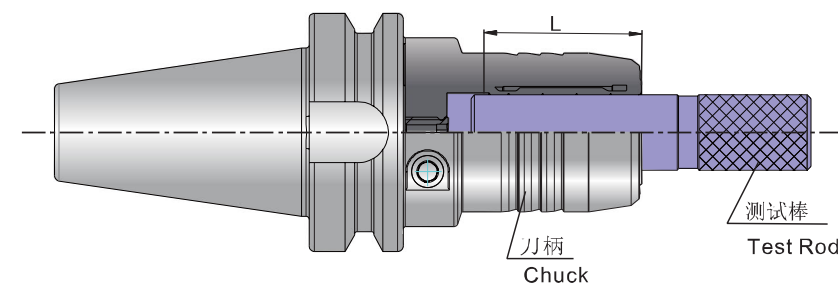

警告:
严禁私自拆装液压刀柄。

Warning:
It is strictly forbidden to disassemble and assemble